

TECHNICAL DATA

Aluminum Body Pressure Rating: 210 bar
Ductile Iron Body Pressure Rating: 350 bar

Cavity:
Refer to 11A3
13A2

* Refer to Winner Cartridge Valves Catalog.

Aluminum	0.5 kg(WITHOUT VALVES)

* If you need the special specification. Please contact us.

TYPICAL CIRCUIT:

PORT 2 TO PORT 1
REDUCING

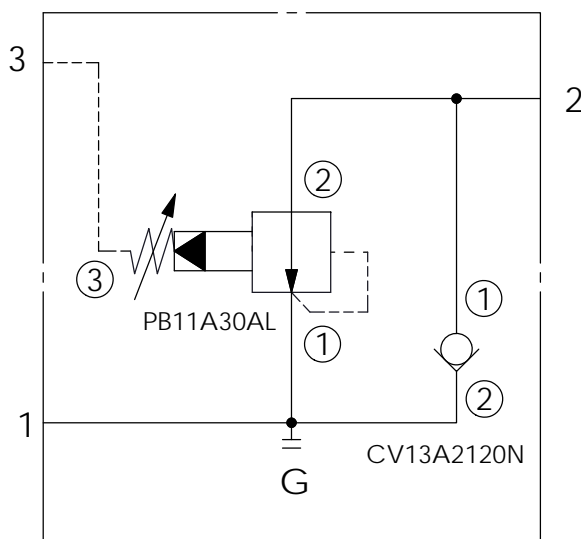

X CARTRIDGE VALVES SELECTION

11A3 CAVITY ONLY(WITHOUT VALVE)

PB0A PB11A30AL (40LPM , 7-210bar)

The selection is only example. Please refer to Winner Cartridge Program and to select the appropriate valves and manifolds assembly in accordance with request function (flow 、 pressure 、 ... etc.)

Y SELECTION FOR SOLENOID VALVES (REFER TO CV13A-X-Y-Z)

13A2 CAVITY ONLY(WITHOUT VALVE)

CV20 CV13A2120N(60LPM,2.0bar)

The selection is only example. Please refer to Winner Cartridge Program and to select the appropriate valves and manifolds assembly in accordance with request function (flow 、 pressure 、 ... etc.)

PORT SIZE

Z	PORTS		
	1,2	3	G
G03AG	G 3/8"	G 1/4"	G 1/4"