

### TECHNICAL DATA

Aluminum Body Pressure Rating: 210 bar  
Ductile Iron  
Body Pressure Rating: 350 bar

Cavity:  
Refer to 2A3

\* Refer to Winner Cartridge Valves Catalog.

Ductile Iron	3.45 kg(WITHOUT VALVES)

\* If you need the special specification.  
Please contact us.

Y	SELECTION FOR V2 PORT CONTROL	
<b>2A3</b>	CAVITY ONLY(WITHOUT VALVE)	
<b>CB3H</b>	CB2A33HL (3:1 , 280bar)	
<b>CO20</b>	CO2A3020N (2.0bar)	

The selection is only example. Please refer to Winner Cartridge Program and to select the appropriate valves and manifolds assembly in accordance with request function (flow 、 pressure 、 ... etc.)

X	SELECTION FOR V1 PORT CONTROL	
<b>2A3</b>	CAVITY ONLY(WITHOUT VALVE)	
<b>CB3H</b>	CB2A33HL (3:1 , 280bar)	
<b>CO20</b>	CO2A3020N (2.0bar)	

Z	PORT SIZE	
	PORTS V1,V2	PORTS C1,C2
<b>G04</b>	G 1/2"	G 1/2"
<b>G06</b>	G 3/4"	G 3/4"

### HYDRAULIC CIRCUITS(WITH VALVES)

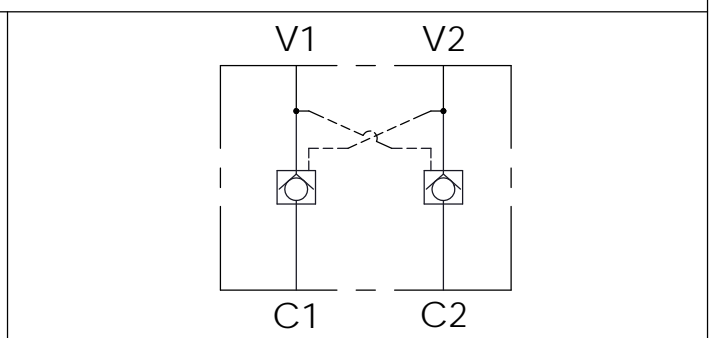
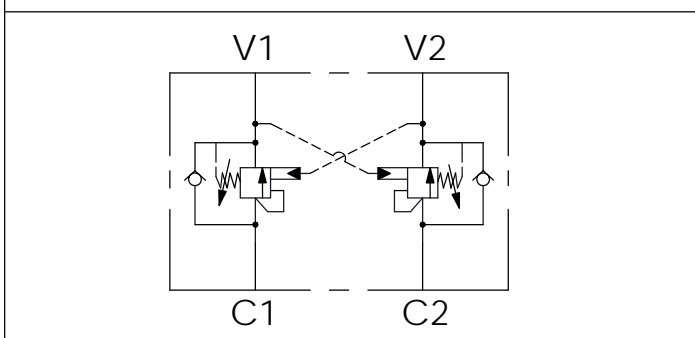

Ordering Code: **ML-120-CDW-CB3H-CB3H-S41**

Ordering Code: **ML-120-CDW-CO20-CO20-S41**