

TECHNICAL DATA

Aluminum Body Pressure Rating: 210 bar
Ductile Iron
Body Pressure Rating: 350 bar

Cavity:
Refer to 2A3

* Refer to Winner Cartridge Valves Catalog.

Ductile Iron	2.21 kg(WITHOUT VALVES)

* If you need the special specification.
Please contact us.

Z	PORT SIZE		
	PORTS V1,V2	PORTS C1,C2	
G03	G 3/8"	G 3/8"	
G04	G 1/2"	G 1/2"	
S10	SAE 10	SAE 10	
S12	SAE 12	SAE 12	

X	SELECTION FOR V1 PORT CONTROL	
2A3	CAVITY ONLY(WITHOUT VALVE)	
CB3H	CB2A33HL (3:1 , 280bar)	
CO20	CO2A3020N (2.0bar)	

Y	SELECTION FOR V2 PORT CONTROL	
2A3	CAVITY ONLY(WITHOUT VALVE)	
CB3H	CB2A33HL (3:1 , 280bar)	
CO20	CO2A3020N (2.0bar)	

HYDRAULIC CIRCUITS(WITH VALVES)

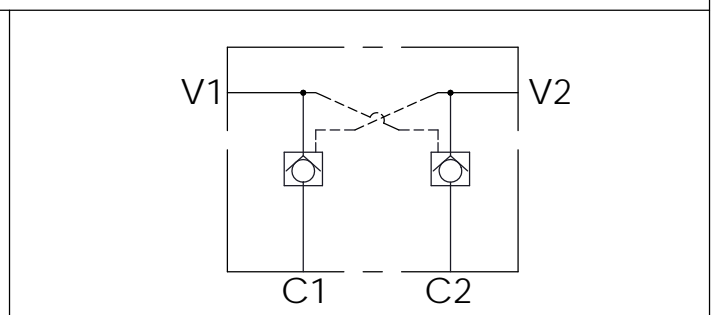
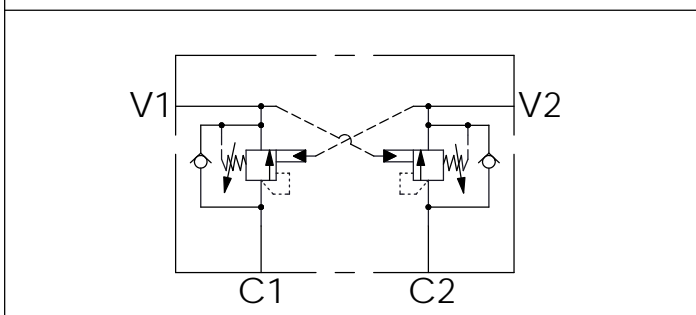

Ordering Code: ML-120-CDW-CB3H-CB3H-S01

Ordering Code: ML-120-CDW-CO20-CO20-S01