

Ordering Code: **ML-24A4-X-Y 01-Z**

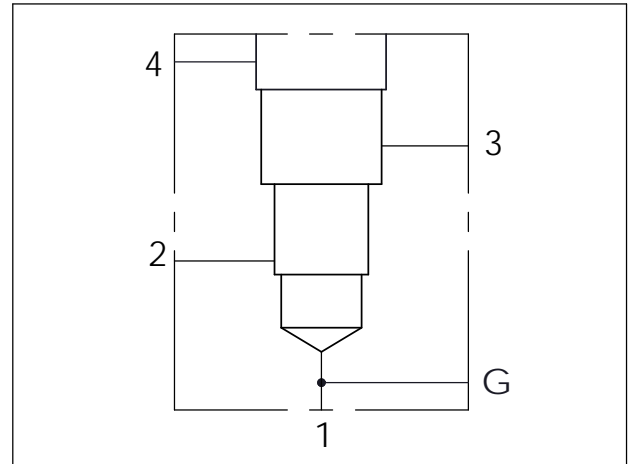
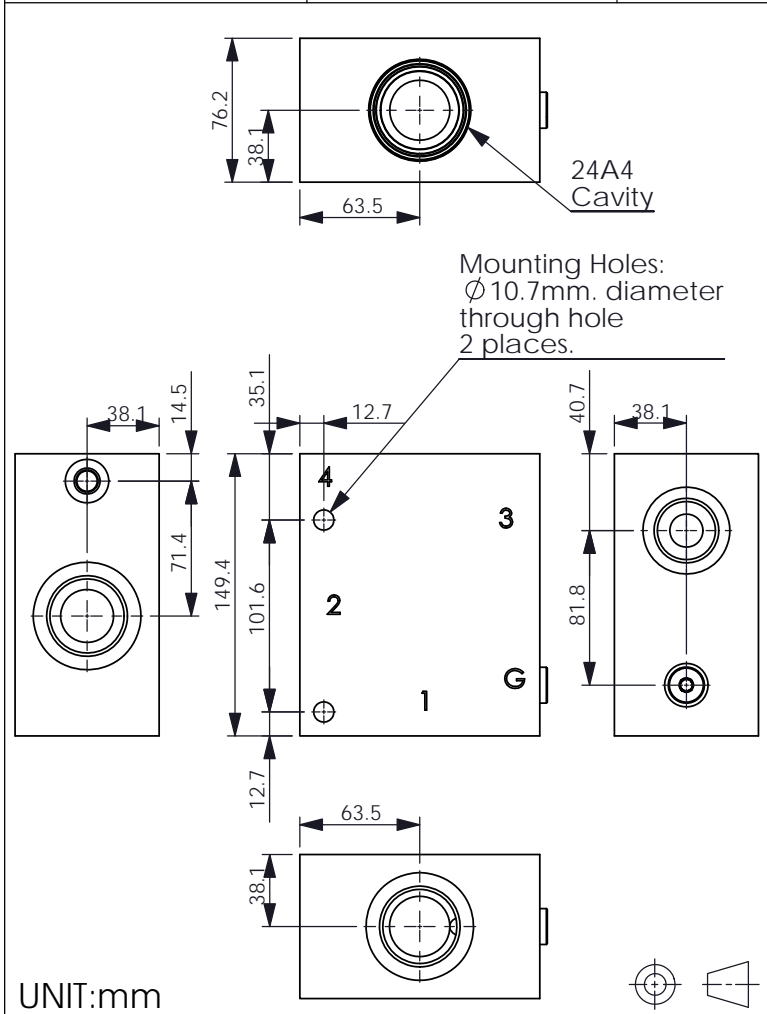

TECHNICAL DATA

Aluminum Body Pressure Rating: 210 bar
Ductile Iron Body Pressure Rating: 350 bar

Cavity:

Refer to 24A4

* Refer to Winner Cartridge Valves Catalog.

Aluminum	3.1 kg(WITHOUT VALVES)
Ductile Iron	8.5 kg(WITHOUT VALVES)

* If you need the special specification.
Please contact us.

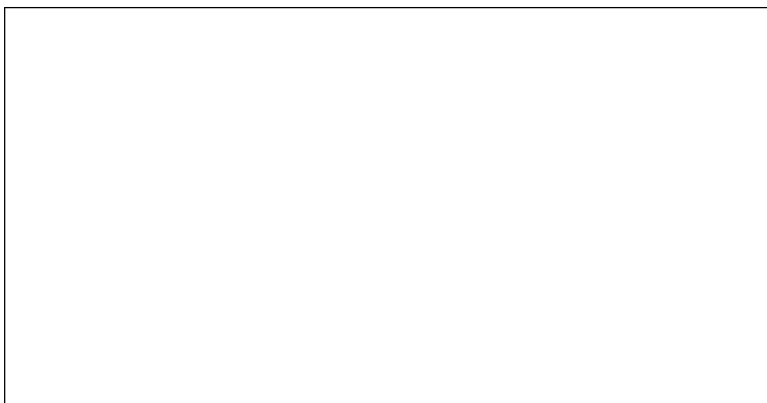

X	PORT SIZE			
	PORTS	PORT	PORT	PORT
	1,2	3	4	G
G08AG	G1"	G1"	G1/4"	G1/4"
G10AG	G1-1/4"	G1"	G1/4"	G1/4"

Y	BODY MATERIAL	
A	HIGH-STRENGTH ALUMINUM	
S	DUCTILE IRON	

Z	CARTRIDGE VALVES SELECTION	
	WITHOUT VALVE	
PV0A	PV24A40AL (320LPM,7-210bar)	

The selection is only example. Please refer to Winner Cartridge Program and to select the appropriate valves and manifolds assembly in accordance with request function (flow 、 pressure 、 ... etc.)